

DUAL PLATE WAFER CHECK VALVE

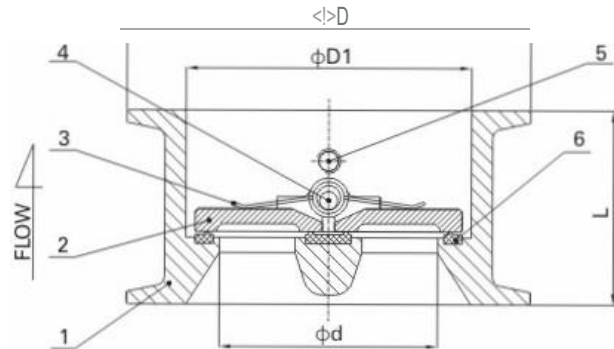

MV-52D

DIN EN1092-1 PN10~PN40

ANSI B16.5 Class150~Class300

EN558-1 (DIN3202-K3)

- Viton/EPDM/
- PN40
- -25°C~+180°C
- CF8M, CF8, CF3M, WCB

- Investment castings for body and disc
- Flanged ends: DIN EN1092-1 PN10~PN40
ANSI B16.5 Class150~Class300
- Face to face: EN558-1 (DIN3202-K3)
- Seal: Viton/EPDM/Metal-to-Metal
- Pressure rating: PN40
- Working temperature: -25°C~+180°C
- Material: CF8M, CF8, CF3M, WCB

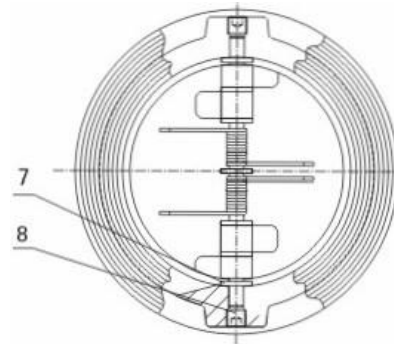

MATERIAL LIST

ITEM	PART	MATERIAL	QTY.
1	Body	CF8M	1
2	Disc	CF8M	2
3	Spring	SS316	2
4	Axle	SS316	1
5	Disc Stopper	SS316	1
6	Seat	VITON	1
7	Washer	PTFE	7
8	Plug	SS316	4

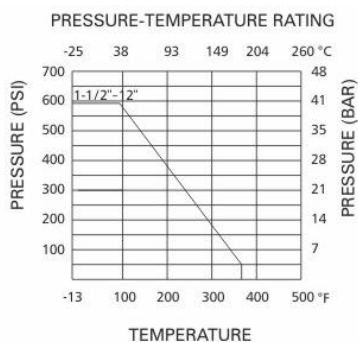

DIMENSION LIST

SIZE	ϕd	ϕD	$\phi D1$	L	Kgs
DN40	38	84	60	43	0.78
DN50	48	101	65	43	1.05
DN65	59	120	80	46	1.45
DN80	72	133	94	64	2.32
DN100	90	162	117	64	3.36
DN125	110	192	145	70	5.26
DN150	135	218	170	76	7.15
DN200	175	273	224	89	11.84
DN250	222	328	265	114	20.36
DN300	264	378	310	114	28.34