

2-PC FLANGE BALL VALVE

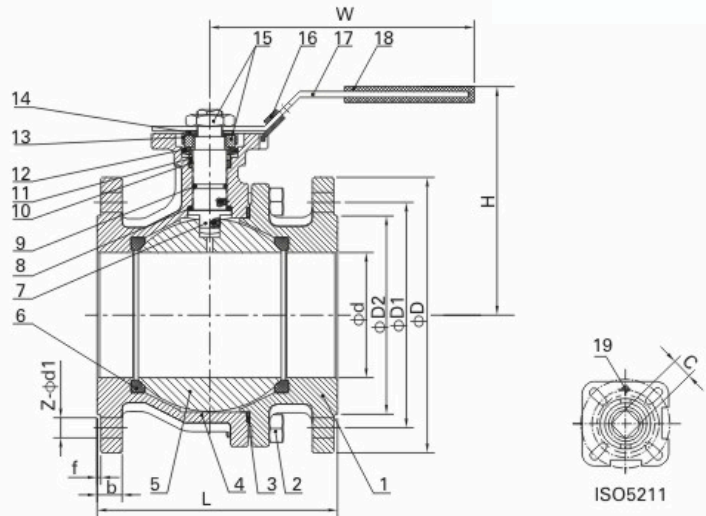
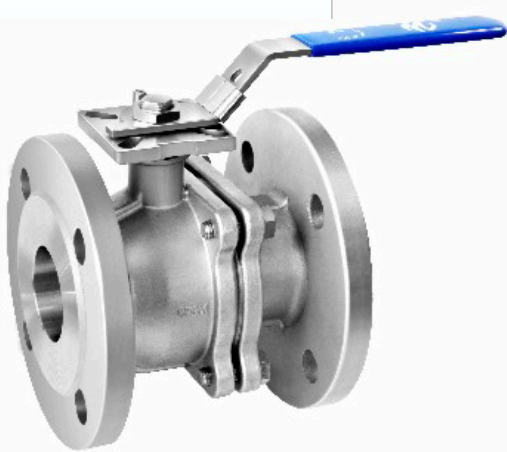

MV-24D (DN15~DN100)

- Investment casting for body and cap
- Fire-safe design
- Flanged ends: DIN EN1092-1 PN10~PN40
- Face to Face: EN558 Series27
DIN3202 F4
- Mounting Pad: ISO5211
- Pressure rating: PN10~PN40
- Working temperature: -25°C~+ 180°C
- Material: CF8M, CF8, CF3M, WCB

MATERIAL LIST

ITEM	PART	MATERIAL	QTY.
1	Cap	CF8M	1
2	Bolt	SS304	4/6/8
3	Body Gasket	PTFE	1
4	Body	CF8M	1
5	Ball	SS316	1
6	Ball Seat	R-PTFE(15%)	2
7	Stem	SS316	1
8	Thrust Washer	PTFE	1
9	O- Ring	VITON	1
10	Stem Packing	PTFE	1
11	Stem Ring	SS316	1
12	Belleville Washer	SS301	2
13	Nut Stopper	SS304	1
14	Plate Washer	SS304	1
15	Nut	SS304	2
16	Lock Device	SS304	1
17	Handle	SS304	1
18	Plastic Cover	PLASTIC	1
19	Stop Pin	SS304	1

PRESSURE-TEMPERATURE RATING

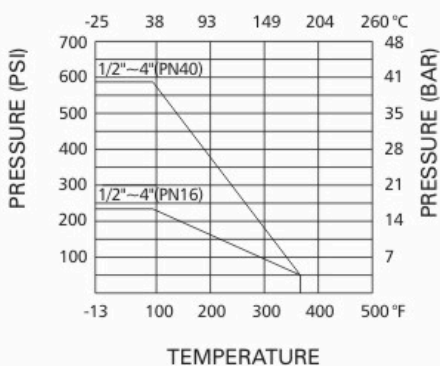

DIMENSION LIST

SIZE	PN	d	L	D	D1	D2	b	f	H	W	C	ISO5211	Z-φd1	N-m
DN15	10~40	15	115	95	65	45	16	2	82	117	9	F03/F04	4-φ14	5
DN20	10~40	20	120	105	75	58	18	2	87	117	9	F03/F04	4-φ14	8
DN25	10~40	25	125	115	85	68	18	2	90	164	11	F04/F05	4-φ14	10
DN32	10~40	32	130	140	100	78	18	2	100	164	11	F04/F05	4-φ18	14
DN40	10~40	40	140	150	110	88	18	3	116	203	14	F05/F07	4-φ18	18
DN50	10~40	50	150	165	125	102	20	3	125	203	14	F05/F07	4-φ18	25
DN65	10/16	65	170	185	145	122	18	3	164	255	17	F07/F10	8-φ18	48
	22													
DN80	10/16	80	180	200	160	138	20	3	174	255	17	F07/F10	8-φ18	75
	24													
DN100	10/16	100	190	220	180	158	20	3	200	302	17	F07/F10	8-φ18	110
	24													