

M 3-PC. BUTT WELD END BALL VALVE

2012N

FEATURES



- Full port, 1/4"~4" (DN8~DN100)
- W.P. : 1000 WOG (PN63)
- W.T. : -20°C~200°C (-4°F~392°F)
- Investment casting
- Blow-out proof stem
- Locking device
- TA-Luft approved (option)
- Length conform to DIN 3202/4-M3-2012N-M3 (option)
- Butt weld ends conform to ANSI B16.25 & DIN 3239 part 1

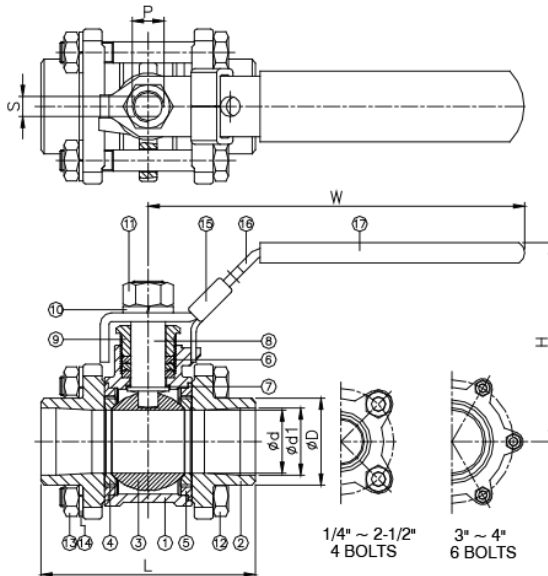

ITEM	PARTS	MATERIAL	
1	BODY	ASTM A351-CF8M	ASTM A216-WCB
2	CAP		
3	BALL	ASTM A351-CF8M	
4	SEAT	PTFE / RTFE	
5	SEAL	PTFE	
6	PACKING		
7	THRUST WASHER	ASTM A276-316	
8	STEM		
9	GLAND	AISI 304	
10	SPRING WASHER		
11	STEM NUT		
12	BOLT		
13	NUT	STAINLESS STEEL	
14	SPRING WASHER		
15	LOCKING DEVICE	PVC	
16	HANDLE		
17	HANDLE SLEEVE		

DN	d	d1	D	L	H	W	S	P	Torque (N-M)	Weight (kg)
8	9.3	-	14.7	65	60.2	98	5	3/8"-24UNF	3.5	0.4
10	12.5	-	18.1	65	60.2	98	5	3/8"-24UNF	4	0.4
15	15	15.8	22.3	65	62.2	98	5	3/8"-24UNF	5.5	0.5
20	20	20.9	27.7	75	64.6	121	6.5	7/16"-20UNF	7.5	0.7
25	25	26.6	34.4	85	80.1	147	8	7/16"-20UNF	11	1.1
32	32	35.1	43.2	101	85.1	147	8	7/16"-20UNF	15	1.6
40	38	40.9	49.3	112	103.3	188	10	1/2"-20UNF	20	2.4
50	50	52.5	61.5	130	110.8	188	10	1/2"-20UNF	40	3.1
65	63	62.7	74.5	162	141.7	245	12	3/4"-10UNC	60	6.5
80	76	77.9	91	188	150.4	245	12	3/4"-10UNC	85	9.5
100	96	102	115.5	224	181.7	316	16	1"-8UNC	150	19

unit:mm

NPS	d	d1	D	L	H	W	S	P	Torque (in-lb)	Weight (lb)
1/4"	0.37	-	0.58	2.56	2.37	3.86	0.2	3/8"-24UNF	31	0.8
3/8"	0.49	-	0.71	2.56	2.37	3.86	0.2	3/8"-24UNF	35.4	0.8
1/2"	0.59	0.62	0.88	2.56	2.45	3.86	0.2	3/8"-24UNF	48.7	1.1
3/4"	0.79	0.82	1.09	2.95	2.54	4.76	0.26	7/16"-20UNF	66.4	1.5
1"	0.98	1.05	1.35	3.35	3.15	5.79	0.31	7/16"-20UNF	97.4	2.3
1-1/4"	1.26	1.38	1.7	3.98	3.35	5.79	0.31	7/16"-20UNF	132.8	3.5
1-1/2"	1.5	1.61	1.94	4.41	4.07	7.4	0.39	1/2"-20UNF	177	5.3
2"	1.97	2.07	2.42	5.12	4.36	7.4	0.39	1/2"-20UNF	354	6.8
2-1/2"	2.48	2.47	2.93	6.38	5.58	9.65	0.47	3/4"-10UNC	531	14.3
3"	2.99	3.07	3.58	7.4	5.92	9.65	0.47	3/4"-10UNC	752.3	20.9
4"	3.78	4.02	4.55	8.82	7.15	12.44	0.63	1"-8UNC	1327.6	41.9

unit:in