

V-VALFLOW

2-PC BALL VALVE

MV-21N



- Investment casting for body and cap
- Full bore
- Thread: ISO, BS, DIN, JIS, ASME
- Pressure rating: 1000 PSI (PN63)
- Working temperature: -25°C~+ 180°C
- Material: CF8M, CF8, CF3M, WCB

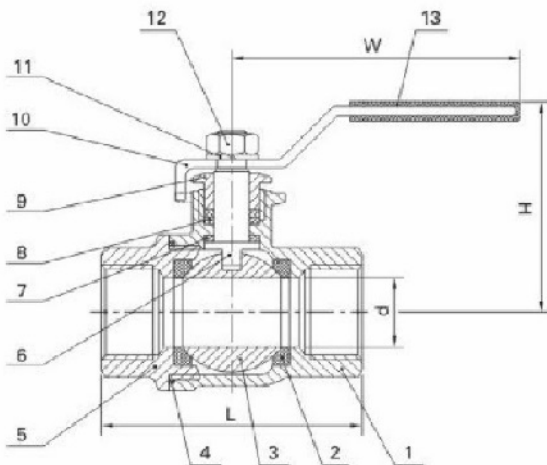

MATERIAL LIST

ITEM	PART	MATERIAL	QTY.
1	Body	CF8M	1
2	Ball Seat	R-PTFE(15%)	2
3	Ball	SS316	1
4	Body Gasket	PTFE	1
5	Cap	CF8M	1
6	Stem	SS316	1
7	Thrust Washer	PTFE	1
8	Stem Packing	PTFE	2
9	Gland Nut	SS304	1
10	Handle	SS304	1
11	Spring Washer	SS304	1
12	Nut	SS304	1
13	Handle Cover	PLASTIC	1

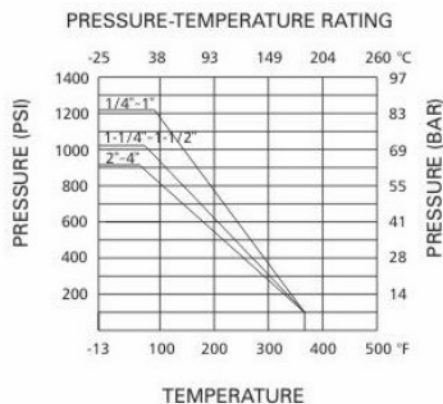

DIMENSION LIST

SIZE	d	L	H	W	N-m	Kgs
1/4"	11.5	50	52	95	4	0.17
3/8"	12.5	50	52	95	4	0.16
1/2"	15	55	53	100	5	0.22
3/4"	20	65	61	110	8	0.34
1"	25	75	70	115	10	0.50
1-1/4"	32	85	80	130	14	0.84
1-1/2"	38	95	80	155	18	1.22
2"	50	110	93	171	25	1.96
2-1/2"	65	145	117	243	48	4.25
3"	76	165	131	243	75	6.21
4"	94	208	167	274	110	11.10