



PRESSURE RELIEF VALVES

**Globe Type / Model 50B-4KG1
Angle Type / Model 2050B-4KG1**



U.L. Listed.....Sizes 3" thru 8"
F.M. Approved.....Sizes 3" thru 8"
U.L.C. Listed.....Sizes 2" thru 10"

Features

- Fast Opening to Maintain Steady Line Pressure
- Accommodates Wide Range of Flow Rates
- Closes Gradually for Surge-Free Operation
- Adjustable Pressure Settings, Not Affected by Pressure At Valve Discharge

The Model 50B-4KG1 Globe / 2050B-4KG1 Angle Pressure Relief Valve is designed specifically to automatically relieve excess pressure in fire protection pumping systems. Pilot controlled, it maintains constant system pressure at the pump discharge within very close limits as demands change. The 50B-4KG1 and 2050B-4KG1 can be supplied with optional internal and external epoxy coating of the main valve wetted surfaces.

Typical Application

At pump start, Relief Valve modulates to relieve excess pump capacity, maintaining positive system pressure at the pump discharge. When fire demand slows or ceases, Model 50B-4KG1 opens, diverting entire pump output to discharge, allowing fire pump to be stopped without causing surging in the lines. (Please note that if the Model 50B-4KG1 is to be used on a continuous duty basis to maintain fire-system pressure, suitable back pressure must be provided on the valve to prevent cavitation damage. Consult the factory for details.)

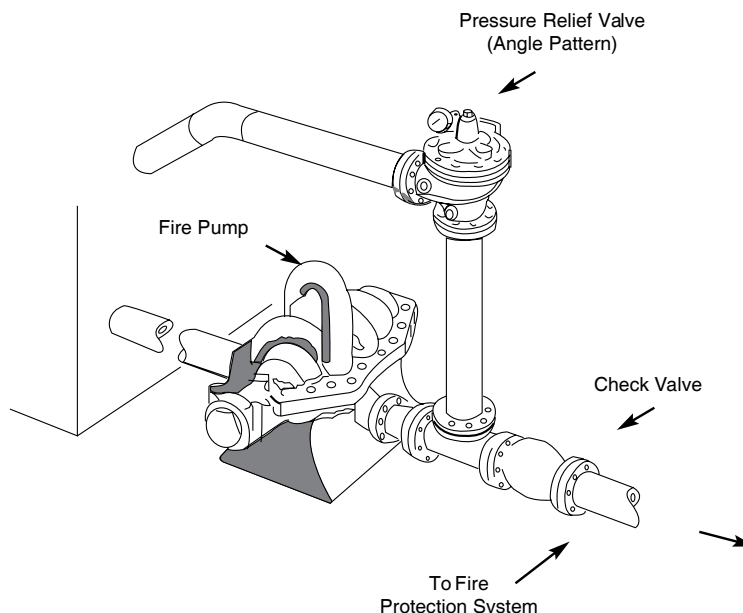

Specifications

Size	: Globe: 2" - 10" flanged Angle: 2" - 10" flanged
End Details & Pressure Ratings	: Class 150 ANSI B16.42 (175PSI) and Class 300 ANSI B16.42 (300PSI)
Temperature Range	: Water to 82°C (180°F) Max.
Pressure Adjustment Range	: 20-200 psi (150 Class) — 100-300 psi (300 Class)

Manufactured by CLA-VAL who have the ULC and UL Listing



PRESSURE RELIEF VALVES

Materials

Main Valve Body & Cover

: Ductile Iron ASTM A-536 — Naval Bronze ASTM B61

Standard Main Valve Trim

: Bronze Seat, Teflon Coated — Stainless Steel Stem, Dura-Kleen Stem

Standard Pilot Control System

: Cast Bronze with Stainless Steel trim

Dimensions

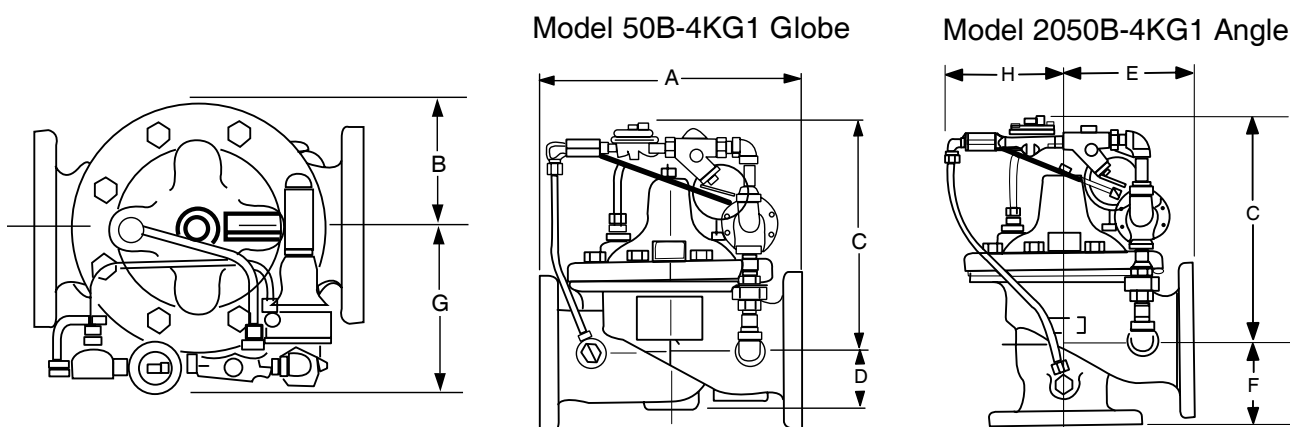

Size (inch)	2"	2 1/2"	3"	4"	6"	8"	10"
Threaded Ends	9,38	11,00	12,50	-	-	-	-
A 150 Flanged	9,38	11,00	12,00	15,00	20,00	25,38	29,75
300 Flanged	10,00	11,62	13,25	15,62	21,00	26,38	31,12
300 X 150	-	-	12,88	15,31	20,56	25,88	30,44
B	3,31	4,00	4,56	5,75	7,88	10,00	11,81
C	12,00	12,25	12,50	13,00	14,31	16,31	18,00
D	1,50	1,69	2,66	3,19	4,31	5,31	9,25
Threaded Ends	4,75	5,50	6,25	-	-	-	-
E 150 Flanged	4,75	5,50	6,00	7,50	10,00	12,75	14,88
300 Flanged	5,00	5,88	6,38	7,88	10,50	13,25	15,56
Threaded Ends	3,25	4,00	4,50	-	-	-	-
F 150 Flanged	3,25	4,00	4,00	5,00	6,00	8,00	8,62
300 Flanged	3,50	4,31	4,38	5,31	6,50	8,50	9,31
G & H	6,00	6,69	7,75	7,88	8,50	9,75	13,25

Size (mm)	50	65	80	100	150	200	250
Threaded Ends	238	279	318	-	-	-	-
A 150 Flanged	238	279	305	381	508	645	756
300 Flanged	254	295	337	397	533	670	790
300 X 150	-	-	327	389	522	657	773
B	84	102	116	146	200	254	300
C	305	311	318	330	363	414	457
D	38	43	68	81	109	135	235
Threaded Ends	121	140	159	-	-	-	-
E 150 Flanged	121	140	152	191	254	324	378
300 Flanged	127	149	162	200	267	337	395
Threaded Ends	83	102	114	-	-	-	-
F 150 Flanged	83	102	102	127	152	203	219
300 Flanged	89	109	111	135	165	216	236
G & H	152	170	197	200	216	248	337