

# VALVULAS DE GUILLOTINA Serie-L PROGRAMA DE FABRICACION

## KNIFE GATE VALVES L-Series FABRICATION RANGE

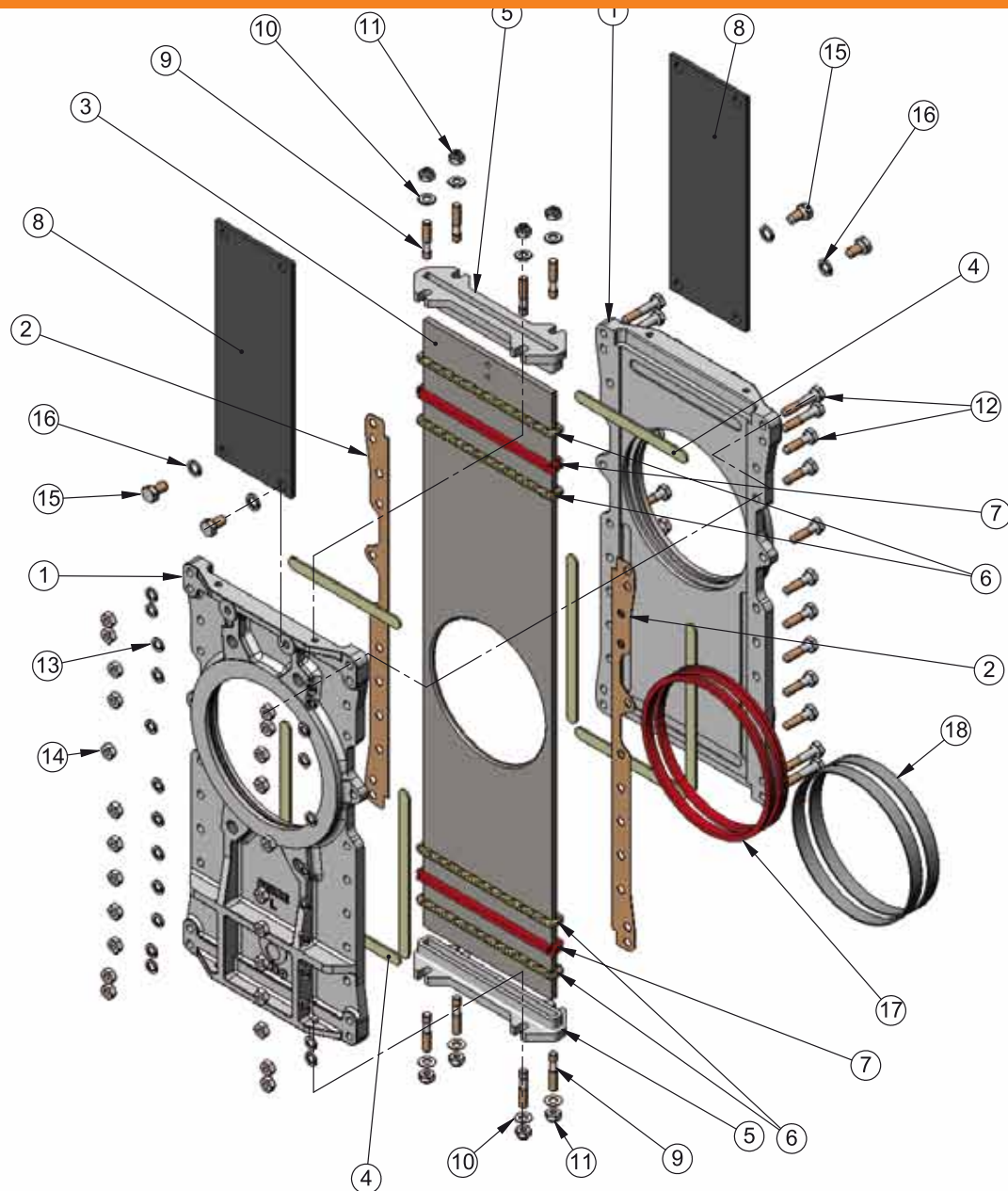

POS.	DESCRIPCION / DESCRIPTION	GJL 250	CF8M
1	CUERPO / BODY	GJL 250	CF8M
2	JUNTA ASIENTO / BED JOINT	CARTON / CARDBOARD	CARTON / CARDBOARD
3	TAJADERA / KNIFE	AISI-304	AISI-316
4	ASIENTO / GUIDE	---	RCH 1000
5	PRENSAESTOPAS / PACKING GLAND	GJS 500	CF8M
6	EMPAQUETADURA / PACKING	SYNT + PTFE	SYNT + PTFE
7	JUNTA / JOINT	EPDM	EPDM
8	SOPORTE / SUPPORT	S275JR	S275JR
9	ESPARRAGO / STUD	F-111 ZINC	AISI-316
10	ARANDELA / WASHER	ST ZINC	A-4
11	TUERCA AUTOBLOCANTE / SELF-LOCKING NUT	5.6 ZINC	A-4
12	TORNILLO / SCREW	5.6 ZINC	A-4
13	ARANDELA / WASHER	ST ZINC	A-4
14	TUERCA / NUT	5.6 ZINC	A-4
15	TORNILLO / SCREW	5.6 ZINC	A-2
16	ARANDELA / WASHER	ST ZINC	A-2
17 *	CIERRE / SEAT	EPDM	EPDM
18 *	ANILLO / SOCKET	AISI-316	AISI-316

\* → Estos elementos son opcionales  
These elements are optional

CONSTRUCCIONES METALICAS DE OBTURACION, S.L.



VÁLVULAS Y COMPUERTAS

Tel.: (+34) 902 40 80 50 - (+34) 943 67 33 99  
Fax: (+34) 902 40 80 51 - (+34) 943 67 24 40  
MADRID - BARCELONA - TOLOSA (SPAIN)  
E-mail: cmo@cmo.es Web: www.cmo.es



**- UTILIZACIÓN:**

Válvula de tajadera bidireccional para productos líquidos cargados con sólidos blandos en porcentajes de hasta el 30%.

No presenta ni resaltes ni hendiduras en la tubería. Aplicación principal: tubería en línea, entre bridas.

**- UTILIZATION:**

Extra-flat bidirectional knife gate valve, for liquid products mixed with soft solids until 30%.

It does not present neither salient nor any split in the pipe.

Main application: pipe en line, between flanges.



GESTION DE LA CALIDAD CERTIFICADA

QUALITY MANAGEMENT CERTIFIED





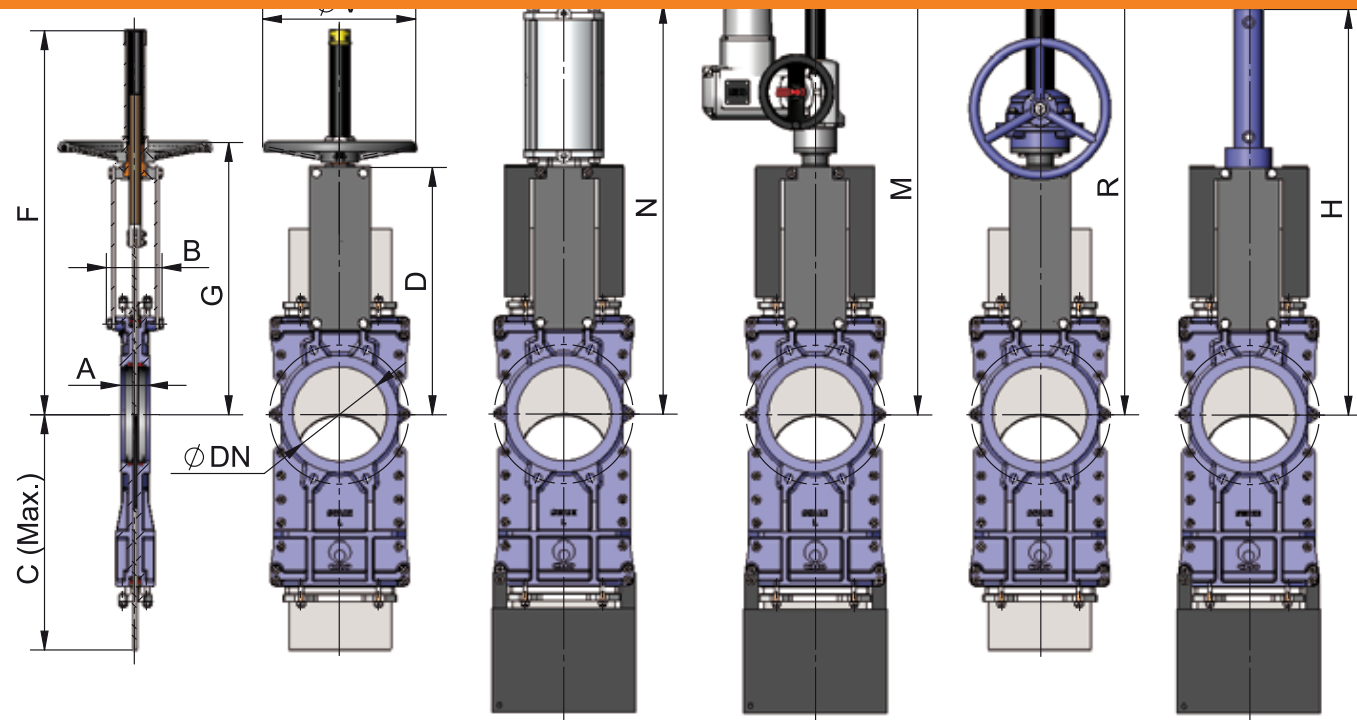

**DIMENSIONES / DIMENSIONS**

DN	A	B	C	D	F	G	ØV	N	M	R	H
50	40	91	225	243	412	282	225	416	581	540	459
65	40	91	265	269	437	308	225	456	607	566	500
80	50	91	310	293	462	332	225	497	631	591	559
100	50	91	370	334	503	373	225	561	671	631	620
125	50	101	430	367	586	407	225	636	705	665	683
150	60	101	495	419	638	458	225	717	757	717	755
200	60	118	630	525	816	578	325	874	988	943	927
250	70	118	770	620	1011	673	325	1030	1083	1037	1071
300	70	118	895	704	1095	757	380	1160	1167	1171	1223
350	96	290	1050	780	1320	889	460	1364	1285	1318	1360
400	100	290	1185	855	1395	964	460	1482	1410	1393	1484
450	106	290	1320	975	1614	1083	460	1662	1740	1662	1693
500	110	290	1455	1064	1704	1173	460	1802	1829	1752	1832
600	110	290	1720	1244	1983	1352	460	2081	2008	1981	2111
700	110	320	1995	1425	---	---	---	2400	2310	2320	2444
800	110	320	2230	1615	---	---	---	2693	2600	2610	2734
900	110	320	2465	1823	---	---	---	3037	2903	2913	3042
1000	110	320	2620	1992	---	---	---	3306	3183	3206	3351
1200	150	340	3250	2351	---	---	---	3868	3782	3777	3910

OBSERVACIONES: Tamaños mayores bajo consulta. / NOTE: Bigger sizes under request.

Cotas y dibujos sin compromiso. CMO S.L. se reserva, en cualquier momento, el derecho de modificarlos a discreción y sin previo aviso.  
Dimensions and drawings without obligation. CMO S.L. reserves, at any moment, the right of their modification at its own discretion and without any previous notice.

● → Agujeros ciegos / Tapped holes    ○ → Agujeros pasantes / Through holes

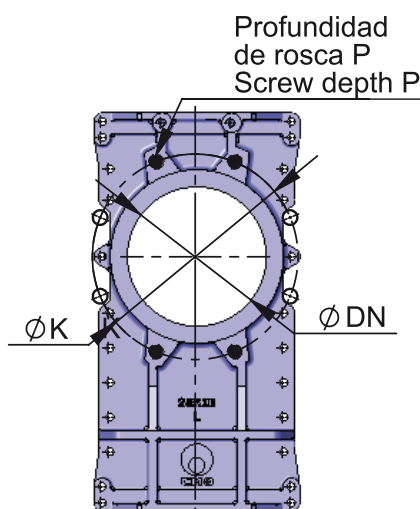

DN	ΔP Kg/Cm <sup>2</sup>	TALADRADO DE BRIDAS / BORING JOINT									
		DIN PN-10					ANSI-150				
		●	○	M Métrico	P	ØK	●	○	R UNC	P	ØK
50	10	4	-	M 16	10	125	4	-	5/8"	10	120,6
65	10	4	-	M 16	10	145	4	-	5/8"	10	139,7
80	10	4	4	M 16	12	160	4	-	5/8"	12	152,4
100	10	4	4	M 16	12	180	4	4	5/8"	12	190,5
125	10	4	4	M 16	12	210	4	4	3/4"	12	215,9
150	8	4	4	M 20	17	240	4	4	3/4"	17	241,3
200	7	4	4	M 20	16	295	4	4	3/4"	16	298,4
250	5	8	4	M 20	19	350	8	4	7/8"	19	361,9
300	5	8	4	M 20	19	400	8	4	7/8"	19	431,8
350	4	12	4	M 20	28	460	8	4	1"	28	476,2
400	4	12	4	M 24	28	515	12	4	1"	28	539,7
450	3	16	4	M 24	28	565	12	4	1 1/8"	28	577,8
500	3	16	4	M 24	34	620	16	4	1 1/8"	34	635
600	3	16	4	M 27	26	725	16	4	1 1/4"	26	749,3
700	3	20	4	M 27	25	840	20	4	1 1/4"	25	863,6
800	3	20	4	M 30	22	950	24	4	1 1/2"	22	977,9
900	3	24	4	M 30	21	1050	28	4	1 1/2"	21	1085,9
1000	3	24	4	M 33	21	1160	32	4	1 1/2"	21	1200,2
1200	3	28	4	M 36	30	1380	40	4	1 1/2"	30	1422,4

OBSERVACIONES: Tamaños mayores bajo consulta. / NOTE: Bigger sizes under request.

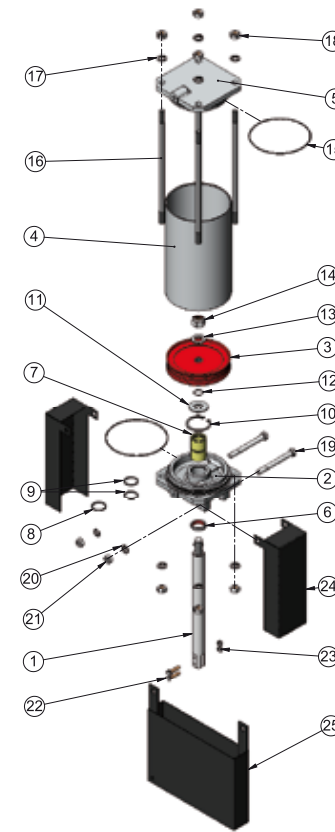

NEUMATICO / PNEUMATIC		
POS.	DESCRIPCION / DESCRIPTION	MATERIAL
1	VASTAGO / STEM	AISI-304
2	TAPA SOPORTE / CYLINDER HEAD Ø CAMISA / CYLINDER > Ø200 →	ALUMINIO / ALUMINIUM GJS 400
3	EMBOLO / PISTON	S275JR + EPDM
4	CAMISA / CYLINDER TUBE	ALUMINIO / ALUMINIUM
5	TAPA SUPERIOR / CYLINDER CAP Ø CAMISA / CYLINDER > Ø200 →	ALUMINIO / ALUMINIUM GJS 400
6	RASCADOR / SCRAPER	NITRILO / NITRILE
7	CASQUILLO / SOCKET	NYLON
8	ANILLO TORICO EXT. / OUTSIDE O-RING	NITRILO / NITRILE
9	ANILLO TORICO INT. / INSIDE O-RING	NITRILO / NITRILE
10	CIR-CLIP	ACERO / STEEL
11	ARANDELA / WASHER	ST ZINC
12	ANILLO TORICO / O-RING	NITRILO / NITRILE
13	ARANDELA / WASHER	ST ZINC
14	TUERCA AUTOBLOCANTE / SELF-LOCKING NUT	5.6 ZINC
15	ANILLO TORICO / O-RING	NITRILO / NITRILE
16	TIRANTES / TIE ROD	F-114 ZINC
17	ARANDELA / WASHER	ST ZINC
18	TUERCA / NUT	5.6 ZINC
19	TORNILLO / SCREW	5.6 ZINC
20	ARANDELA / WASHER	ST ZINC
21	TUERCA / NUT	5.6 ZINC
22	TORNILLO / SCREW	A-2
23	TUERCA AUTOBLOCANTE / SELF-LOCKING NUT	A-2
24	PROTECCIONES SUP. / UPPER PROTECTIONS	S275JR
25	PROTECCION INF. / LOWER PROTECTION	S275JR

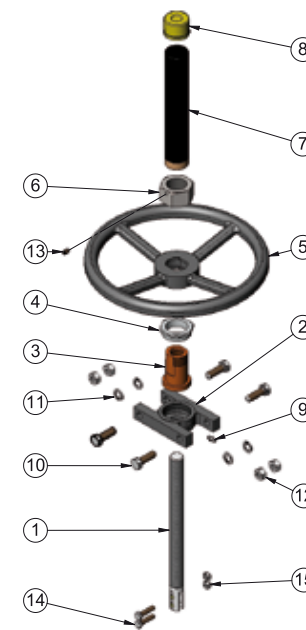

VOLANTE / HANDWHEEL		
POS.	DESCRIPCION / DESCRIPTION	MATERIAL
1	HUSILLO / SPINDLE	AISI-303
2	PUENTE / YOKE	GJL 250
3	TUERCA HUSILLO / SPINDLE NUT	BRONCE / BRONZE
4	TUERCA TOPE / BUTT NUT	F-111
5	VOLANTE / HANDWHEEL	GJS 400
6	TUERCA CAPERUZA / HOOD NUT	5.6 ZINC
7	CAPERUZA / HOOD	ST-37
8	TAPON PROTECCION / PLUG PROTECTION	HD-500
9	ENGRASADOR / GREASER	ACERO / STEEL
10	TORNILLO / SCREW	5.6 ZINC
11	ARANDELA / WASHER	ST ZINC
12	TUERCA / NUT	5.6 ZINC
13	PRISIONERO / SETSCREW	ACERO / STEEL
14	TORNILLO / SCREW	A-2
15	TUERCA AUTOBLOCANTE / SELF-LOCKING NUT	A-2

**HIDRAULICO / HYDRAULIC**

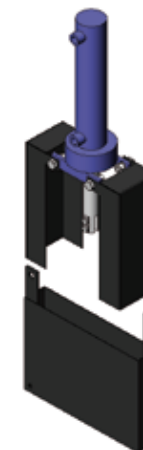

**MOTOR / MOTOR**



**REDUCTOR / SPUR GEAR**

