



GV-16K / GV-25Z / GV-40K

GLOBE VALVE

GENERAL FEATURES

AYVAZ globe valves have a wide range of applications in industry due to its high pressure and temperature resistant structure.

Ayvaz globe valves are flat flow type and their designs consist of body, shaft, flywheel and cap.

Globe valves have taken their names from their global bodies. The body is divided into two parts by means of an internal compartment. Ayvaz globe valves are straight flow type, vertical spindle and T mod-eled valves. Basically, the globe valves regulate the flow (opening-closing) through the movement of the dyskin-sit.

The disc is a threaded shaft controlled by a flywheel. The disc movement is also provided by the flywheel. Through its excellent body and disc design, the Ayvaz globe valves provide smooth laminar flow in pipelines.

Globe type valves have superior resistance to turbulence, internal corrosion and pressure losses.

Application Areas

- Steam boilers and steam systems
- Boiling water systems
- Hot and cold water systems
- Compressed air systems
- Chemical fluids (Acidic and non-alkali fluids)
- Ammonia and oil transfer

		GV-16K					GV-25Z					GV-40K					
PRODUCT SPECIFICATIONS	Body	GG-25 Cast Iron					Spheroidal Graphite Cast Iron					Forged Steel					
	Connection	Flanged					Flanged					Flanged					
	Max. Working Temp. °C	300	250	200	150	120	350	300	250	200	150	120	450	350	250	150	50
	Max. Working Pressure bar	9,6	11,2	12,8	14,4	16	17,5	20	21,8	23	24	25	13,1	25,7	30,4	35,2	40

GV-16K GLOBE VALVE

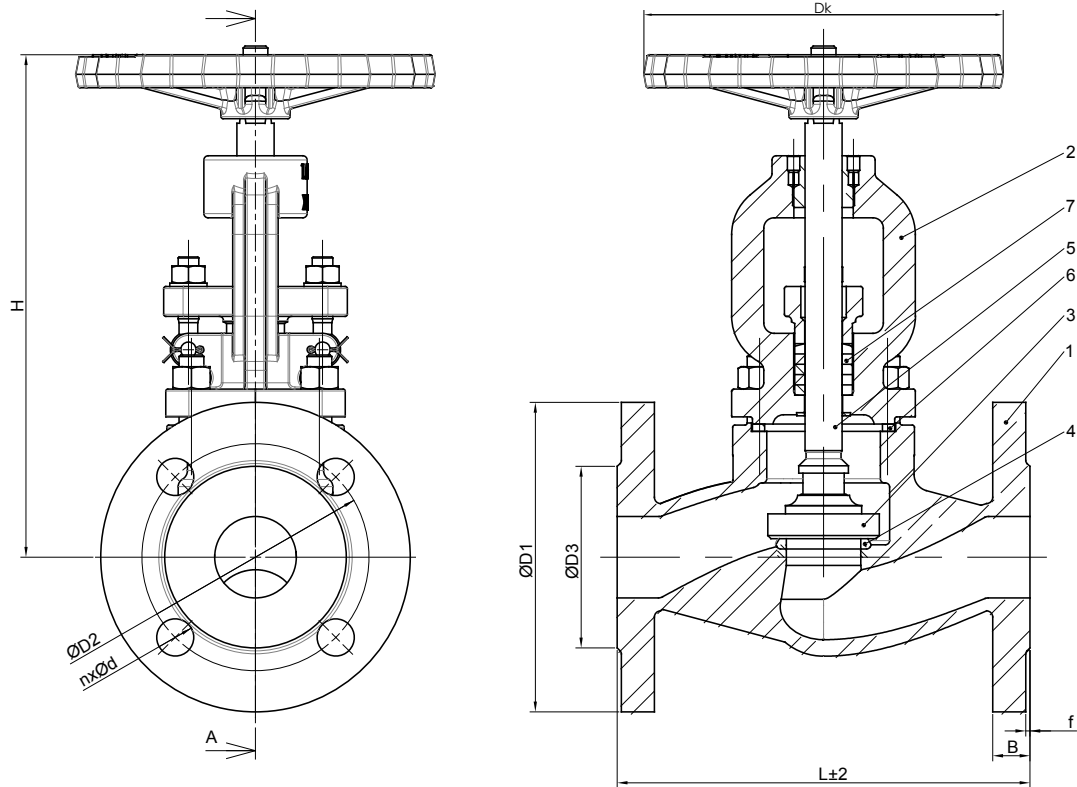

MATERIAL LIST

Part No.	Part Name	Material
1	Body	GG-25 Cast Iron
2	Cover	Z2Cr13
3	Disc	X20Cr13/1.4021 A105+13Cr
4	Bearing	X20Cr13/1.4021
5	Stem	X20Cr13/1.4021
6	Sealing	Graphite/Stainless Steel
7	Sealing Compound	Graphite

GV-16K

DN	PN	D	D2	D3	Dk	B	f	n	d	L	H
15	16	95	65	46	125	14	2	4	14	130	210
20	16	105	75	56	125	16	2	4	14	150	210
25	16	115	85	65	125	16	2	4	14	160	210
32	16	140	100	76	125	18	2	4	19	180	210
40	16	150	110	84	160	18	2	4	19	200	245
50	16	165	125	99	160	20	2	4	19	230	255
65	16	185	145	118	200	20	2	4	19	290	310
80	16	200	160	132	200	22	2	8	19	310	325
100	16	220	180	156	250	24	2	8	19	350	385
125	16	250	210	184	250	26	2	8	19	400	435
150	16	285	240	211	315	26	2	8	23	480	475
200	16	340	295	266	400	30	2	12	23	600	620

GV-25Z GLOBE VALVE

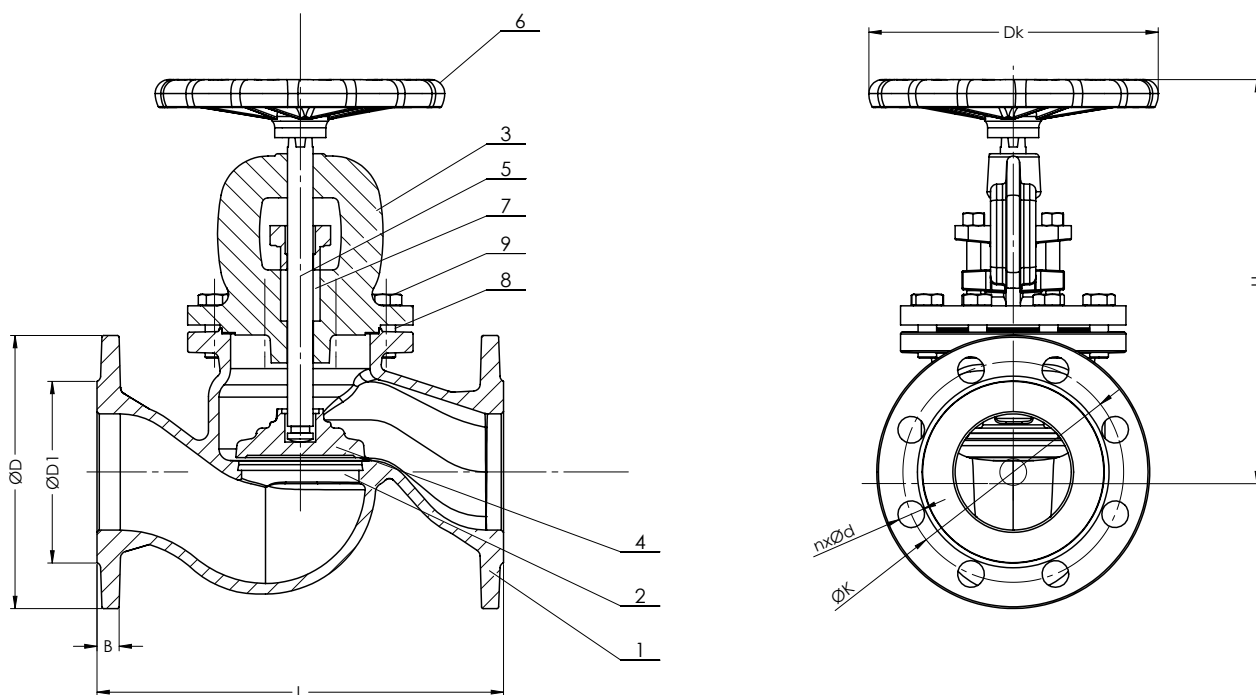

MATERIAL LIST

Parça No.	Part Name	Material
1	Body	Spheroidal Graphite Cast Iron
2	Sealing	X12Cr13(1.4006)
3	Cover	Spheroidal Graphite Cast Iron
4	Disc	X20Cr13(1.4021)
5	Stem	X20Cr13(1.4021)
6	Wheel	EN-GJS-500-7(5.3200)
7	Sealing Compound	Graphite
8	Bolt	A2-70
9	Gasket	Graphite+NiCr

GV-25Z

DN	D	K	B	nxd	L	Dk	H	Kvs(m ³ /h)	Kg
15	95	65	16	4x14	130	100	167	5.9	3.3
20	105	75	16	4x14	150	100	167	7.4	3.9
25	115	85	18	4x14	160	120	175	13	5
32	140	100	19	4x19	180	120	186	18	6.6
40	150	110	19	4x19	200	160	235	30	9.4
50	165	125	19	4x19	230	160	248	41	12
65	185	145	19	8x19	290	180	260	79	17.3
80	200	160	19	8x19	310	200	291	115	22.7
100	235	190	19	8x23	350	250	338	181	35.8
125	270	220	19	8x28	400	250	373	225	52.8
150	300	250	20	8x28	480	320	429	364	74.2
200	360	310	22	12x28	600	360	529	690	126

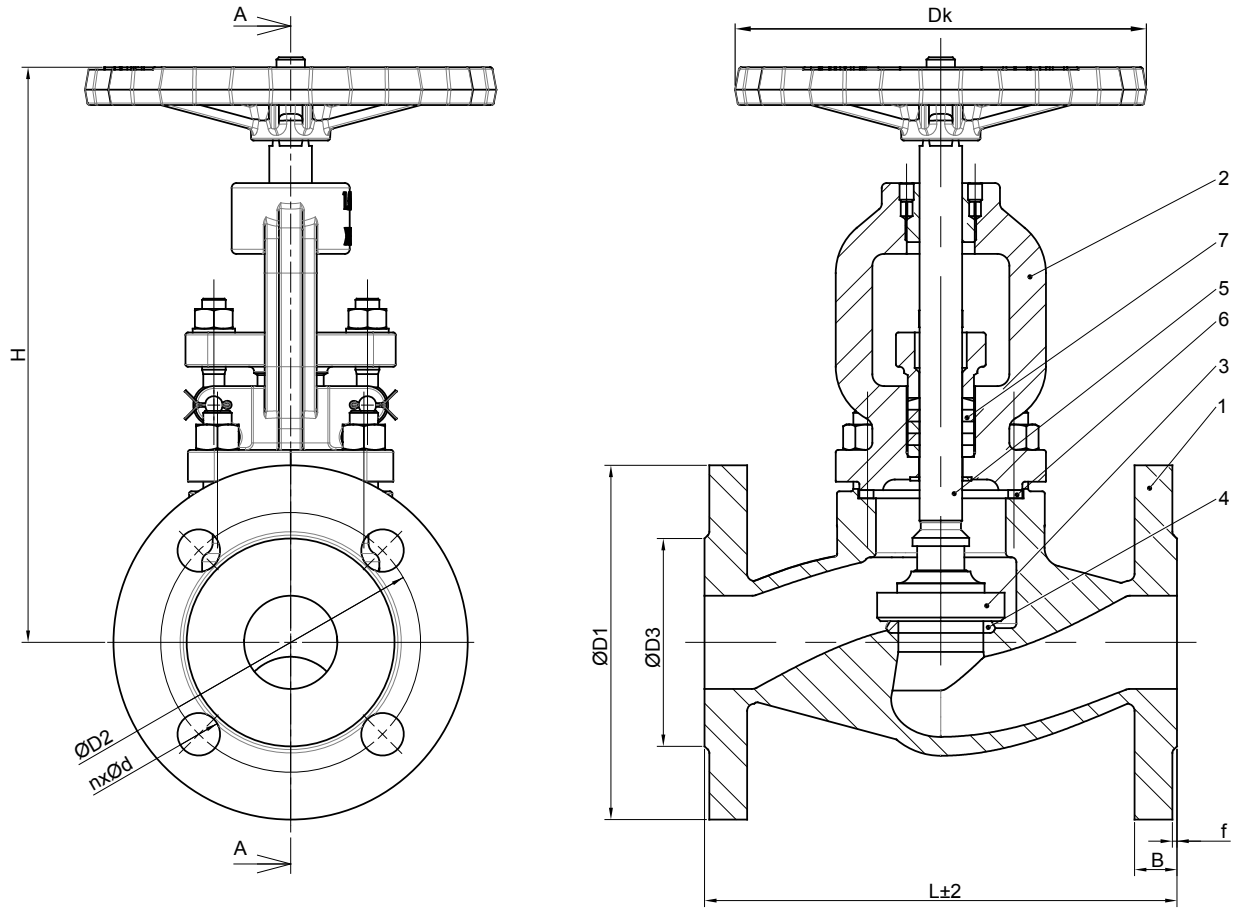
GV-40K GLOBE VALVE



MATERIAL LIST		
Parça No.	Part Name	Material
1	Body	1.0619
2	Cover	1.0619
3	Disc	1.0619+13Cr
4	Bearing	13Cr
5	Stem	1.4021
6	Sealing	Graphite / Stainless Steel
7	Sealing Compound	Graphite

GV-40K											
DN	PN	D1	D2	Dk	D3	B	f	n	d	L	H
15	40	95	65	140	45	16	2	4	14	130	190
20	40	105	75	140	58	18	2	4	14	150	190
25	40	115	85	160	68	18	2	4	14	160	195
32	40	140	100	180	78	18	2	4	18	180	210
40	40	150	110	180	88	18	3	4	18	200	220
50	40	165	125	200	102	20	3	4	18	230	230
65	40	185	145	200	122	22	3	8	18	290	280
80	40	200	160	250	138	24	3	8	18	310	290
100	40	235	190	280	162	24	3	8	22	350	365
125	40	270	220	300	188	26	3	8	26	400	390
150	40	300	250	315	218	28	3	8	26	480	545
200	40	375	320	400	278	34	3	12	30	600	680

GV-16K / GV-25Z / GV-40K GLOBE VALVE

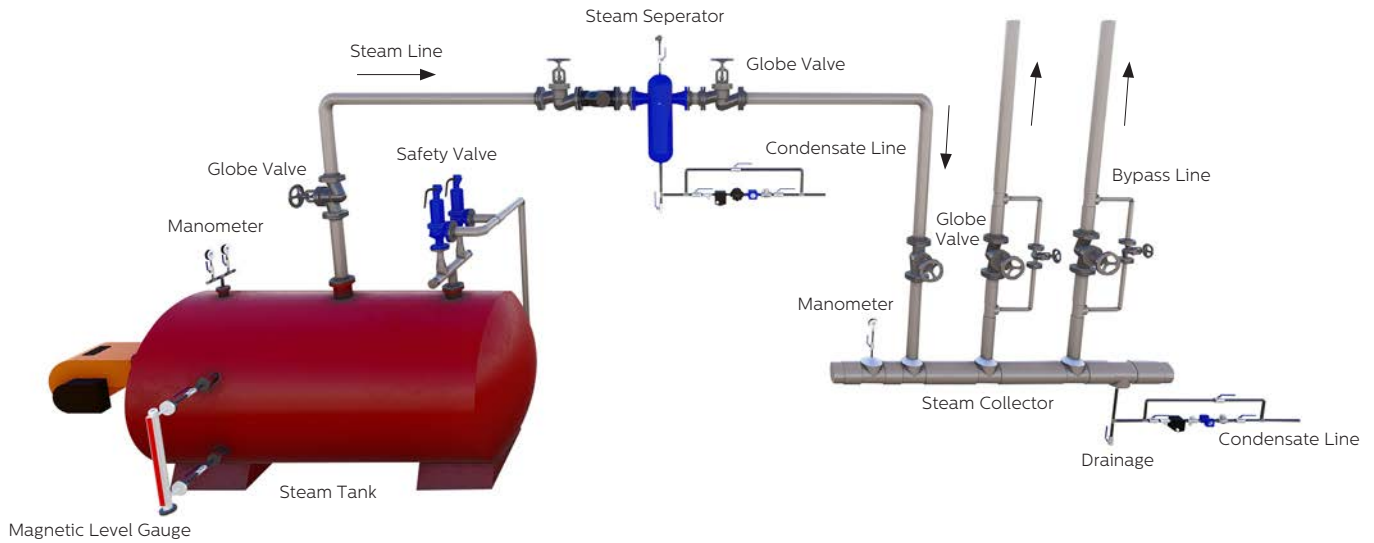

HEAD OFFICE - FACTORY

Atatürk Sanayi Bölgesi Hadımköy Mahallesi Mustafa İnan Caddesi No: 44 Arnavutköy - İSTANBUL
 Tel: +90 212 771 01 45 (pbx) | Fax: +90 212 771 47 27
 info@ayvaz.com | www.ayvaz.com

Cona
 Caserta/Italy
 Tel: +39 0823 187 3988
 rmolaro@ayvaz.com

Ayvaz Russia
 Moscow/Russia
 Tel: +74959951728
 ayvazrus@ayvaz.com

Ayvaz Germany
 Viernheim/Germany
 Tel: +49 62046014399
 germany@ayvaz.com

Ayvaz Ukraine
 Kiev/Ukraine
 Tel: +380 44 390 57 57
 info@ayvaz.com.ua

Tricorr
 Warsaw/Poland
 Tel: +48-32-783-295-1
 tricorr@tricorr.eu

Ayvaz Bakü
 Bakü/Azerbaijan
 Tel: +99(455) 579-84-32
 ahayatov@ayvaz.com

Haci Ayvaz M.E.
 Dubai/U.A.E
 Tel: +971 563550822
 +971 501306871
 mideast@ayvaz.com

Ayvaz China
 Cixi City/China
 Tel: +86 0574 5897 3851
 info@ayvazchina.com

Ayvaz Kazakhstan LLP
 Almaty/Kazakhstan
 Tel: +7 (727) 327 97 57
 info_kz@ayvaz.com
 www.ayvaz.kz

Ayvaz N
 Isperih/Bulgaria
 Tel: +359 8431 27 32
 office@ayvaz-n.eu

Ayvaz Serbia
 Belgrad/Serbia
 Tel: +381 61 658 70 52
 yakbiyik@ayvaz.com

Ayvaz Vietnam
 HCMC/Vietnam
 ggursoy@ayvaz.com